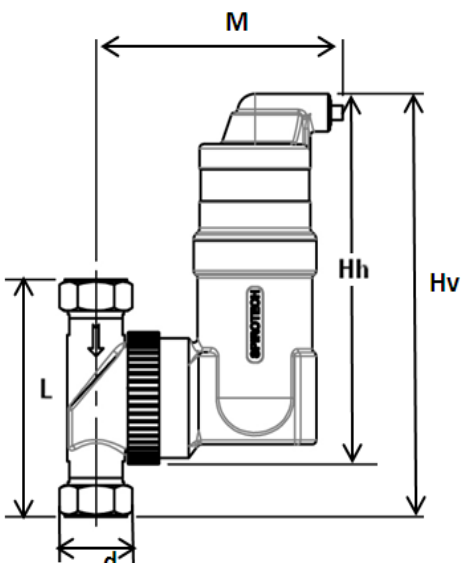

SPIROTECH SPECIFICATION SHEET			
Product: SpiroVent deaerator 22 mm Compression fitting		Type: UA022W	
Customer:		Date: 22-4-2013	
Project:			
Reference:			
Design criteria Medium: Water / glycol (max 50%) Max. flow velocity: 1 m/s Max. flow rate: 0,35 l/s Max. pressure: 6 bar-g Max. temperature: 110 °C Design standard: EN 13445		Drawing: 	
Testing and quality assurance Leakage test: yes Test certificate: no Design and manufacturing acc. 97/23/EC: yes Material certificates (structural parts): no Drawing: no			
Construction materials Body: Brass Deaeration cap: Brass Valve sealing: Viton Float: PP Spirotube Tube: Copper Wire: Copper Solder: Tin(SnCu3)		Dimensions: d 22 mm Hv 205 mm Hh 177 mm L 120 mm M 125 mm Volume: 0,18 ltr Dry weight (approx): 1,8 kg	
Subject to changes			